

SAMPRITI APARTMENT

BY

**SUBIKASH
CONSTRUCTION**



***PROPOSED ELEVATION OF G+IV
RESIDENTIAL CUM COMMERCIAL
BUILDING INTRODUCING BY
SUBIKASH CONSTRUCTION AT
CHISURAH MORE***

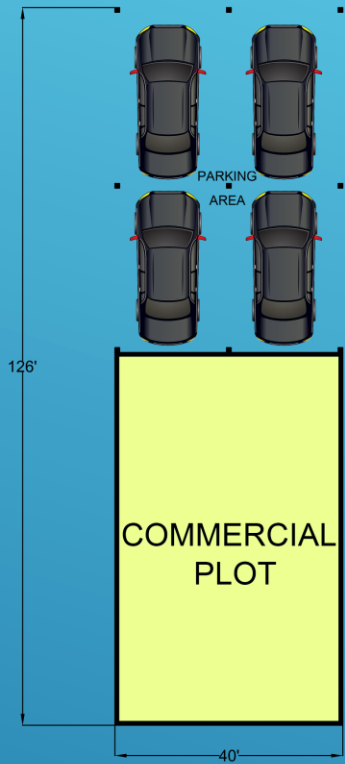

GROUND FLOOR



FIRST FLOOR



SECOND, THIRD AND FORTH FLOOR

PROPOSED SCHEME PLAN FOR G+IV
RESIDENTIAL CUM COMMERCIAL
APARTMENT (SAMPRI TI APARTMENT)

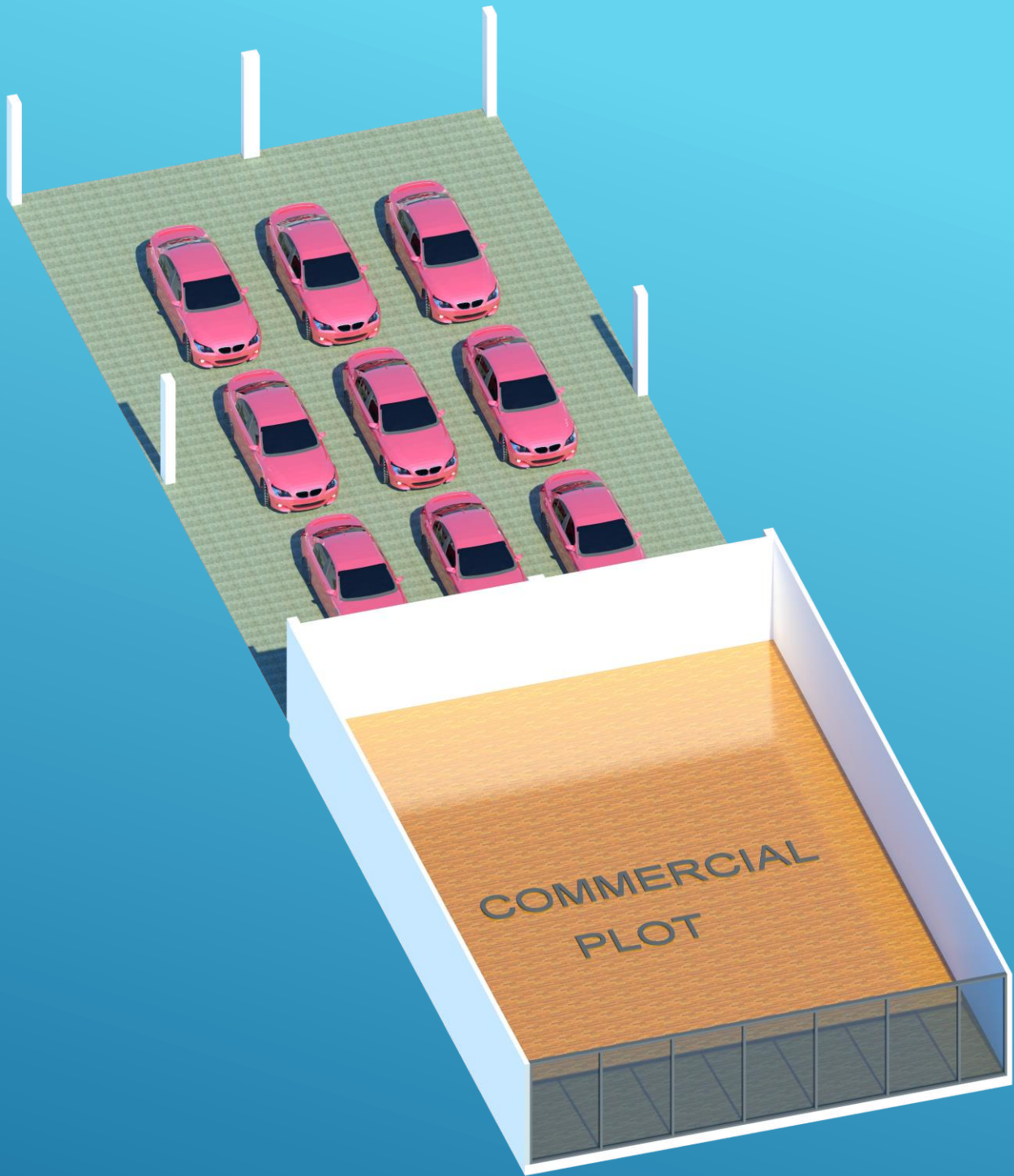

PROPOSED 3D VIEW OF
GROUND FLOOR



PROPOSED 3D VIEW OF A 1BHK FLAT



PROPOSED 3D VIEW OF 2BHK FLAT

FACILITIES

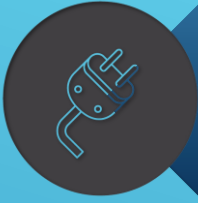

24HRS POWER BACKUP



24HRS WATER SUPPLY



24HRS SECURITY SERVICE



LIFT FACILITY



PARKING SPACE FACILITY



WELL DEFINED
COMMUNICATIONS



EASY ACCESS TO SCHOOL,
COLLEGE, MALL, HOSPITAL,
AIRPORT, AMUSEMENT PARK.

BOOKING GOING ON

CONTACT

SUBIKASH CONSTRUCTION

MR. MAQBOOL HASSAN

CHANAYKYA CENTRE BUILDING,
RAJARHAT MAIN ROAD,
RECKJOANI, RAJARHAT,
KOLKATA - 700135

PH.NO.- 9874405534

Loan Facilities



STATE BANK OF INDIA



LIC HOUSING FINANCE

THANK YOU

HAVE A NICE DAY!

WE HOPE YOU
HAVE
APPRECIATED
OUR PROJECT.